



I-9602LW-NG

Addressable Gas Detector



Description

I-9602LW Series Addressable Gas Detector is used to detect leakage of home use combustible gas (LPG, Natural Gas or Coal Gas) in such areas as houses, hotels and apartments. I-9602LW-NG detector is specified for detection of natural gas. When leakage is detected, the detector will generate high buzzer alert sound, and provide a dry contact to turn exhaust fan, a 12VDC source to switch off the gas valve. The addressable detector can be linked into GST fire alarm system to carry out intelligent control.

Features and Benefits

- Drift compensation, to suit environment changing extensively.
- Electronically addressed
- Local buzzer alarm
- Self-diagnostic
- Relay output for fan control and valve shut off

Certificates and Compliance

- Standards: CE

Terminals and Installation Holes

Below figure shows terminals on the isolator base.

Terminal description:



D1, D2: 24VDC power supply, non-polarized

Z1, Z2: Addressable loop, non-polarized

V+, V-: Connecting with pipe solenoid valve. A 12VDC pulse output to shut off the valve.

K1, K2: 24V/1A normally open contact, closes when detector alarms.

Warning:

It's prohibited to connect 220VAC directly through K1 and K2.

Recommended Cable:

1.0mm² or above Fire-resistant cable for Z1 and Z2

2.5mm² or above Fire-resistant cable for D1 and D2

1.0mm² or above Fire-resistant cable for V+ and V-

1.0mm² or above Fire-resistant cable for K1 and K2

All cables should be subject to local codes.

Application

The detector is wall mounted type with a bracket.

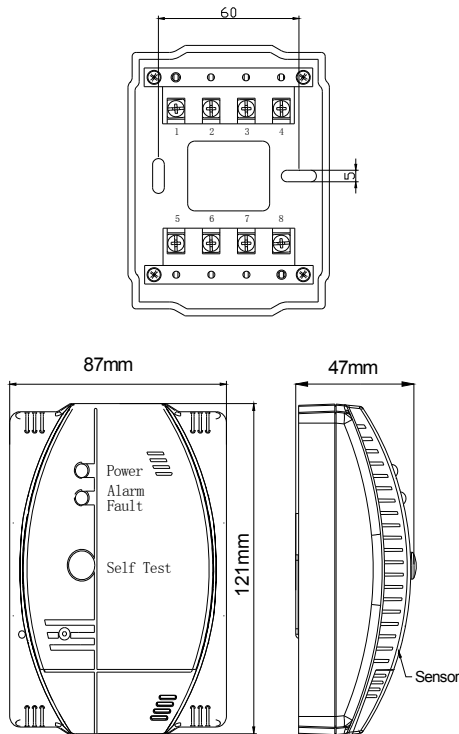

The detector and the gas stove should be placed in the same room. The detector should be mounted above 50cm from the resources or the gas stove. The detector should be within 1.5m ~ 4m to the gas resource or the gas stove.

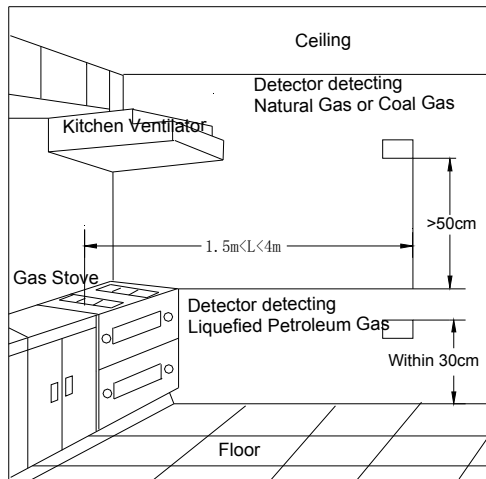

After powered up, the detector will take 3~6 minutes for warm-up well the green LED flashes, and then it will light constantly for normal monitoring.

If the detector alarms, the Alarm/Fault LED flashes red, and the buzzer sounds about twice every second. If the detector is in trouble, the Alarm/Fault LED illuminates yellow steadily, and the buzzer sounds once every 3 seconds.

There is a Self Test button on the detector to test if the LEDs and buzzer works normally. Pressing the Self Test button, the LEDs flash once in turn, and the buzzer sounds three times.

Technical Specification

Working Voltage	24VDC
Power Consumption	Standby: 0.5W Active: 3.0W
Indicator	Power LED: Green Alarm/Fault LED: Dual color, red when alarming, and yellow in fault.
Buzzer	Sounds twice per second when alarming, and once every three seconds in fault.
Self-test	Pressing Self-Test, the LEDs will flash in turn and the buzzer will sound three times.
Type of Gas	Natural gas
Alarm Threshold	6%LEL(methane)
Life of Sensor	5 years
Ingress Protection	IP30
Temperature	-10°C ~ +50°C
Relative Humidity	≤95%, non-condensing
Material	ABS
Weight	180g

1. Avoid using much hair tonic, pesticide, paint, alcohol, diluents etc near the detector.
2. The detector is only sensitive to Natural Gas.
3. Don't install the detector at locations with high temperature (near stoves) or too much oil smoke (near kitchen ventilator).
4. The detector can only control JJ or FCR series solenoid coming with the detector.
5. The detector should be tested every 6 months.
6. The detector can be tested by a lighter. The detector should alarm in about 10 seconds.

Ordering Information

Part No.	I-9602LW-NG
Device Name	Addressable Gas Detector
Order Code	1081648

Accessories and Tools



Part No.: P-9910B
Device name: Handheld Programmer
Order Code: 1274894