



C-9318

Gas Extinguishing Warning Indicator

Description

C-9318 Gas Extinguishing Warning Indicator is the accessory of a gas extinguishing system. It's usually installed above the entrance of the protected area. After gas is released, the control panel will activate the indicator to give visual indication warning people in field to take relative measures.

Terminals and Installation

Below figure shows the back view of the indicator.

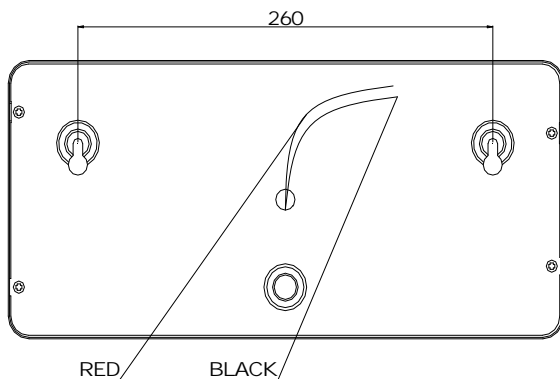

The cables are linked from internal terminals.

XT1 (red): connect to positive "+" of 24VDC or terminal R of the gas extinguishing control panel.

XT2 (black): connect to negative "-" of 24VDC or terminal GND of the gas extinguishing control panel.

1.0mm² or above fire cable is recommended, but subject to local codes.

Variant Models

Part No.	Order Code	Property
C-9318	2345071	порошок НЕ ВХОДИ !
C-9318-RU2	2345149	Russian
C-9318-RU3	2345150	Russian
C-9318-RU4	2345151	Russian

Application

The indicator is wall-mounted type. Hang on the wall and lead the cable to suitable places for junction, or directly connect the cable to internal terminals.

A typical connection is shown below.

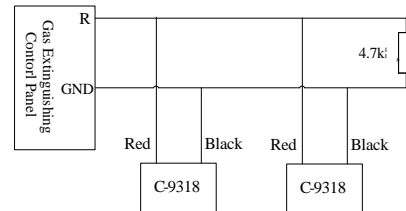

Technical Specification

Operating Voltage	24VDC
Alarm Current	< 50mA
Wiring	Polarized two-wire with power cable
Application Environment	Indoors
Flashing Frequency	1.4Hz±20%
Ambient Temperature	-10°C ~ +50°C
Relative Humidity	≤95%, non-condensing
Dimensions	348mm×159mm×29mm
Material and Color of Enclosure	iron enclosure/ white, with plexi-glass in front/white
Weight	About 990g
Mounting Hole Distance	260mm

Ordering Information and Compatible Products

Part No.	C-9318
Device Name	Gas Extinguishing Warning Indicator
Order Code	2345070
Compatible Products	GST301 Gas Release Control Panel GST303 Gas Extinguishing Control Panel GST306 Gas Extinguishing Control Panel